

PERIBEST I12 DATASHEET

TECHNICAL SPECIFICATIONS	MODEL I12
Max. Flow (continuous)	205 l/h
Capacity	0,043 l/rev
Max. Discharge Pressure	10 bar
Max. Temperature	80 °C
Inner Diameter	13 mm.
Hose material	NR, EPDM, NBR (Food Grade) & Hypalon®
Connections material	AISI-316, PP, PVDF (PTFE)
Pump casign material	Alluminium (powder coated)
Rollers material	Hard alluminium (Anodized)

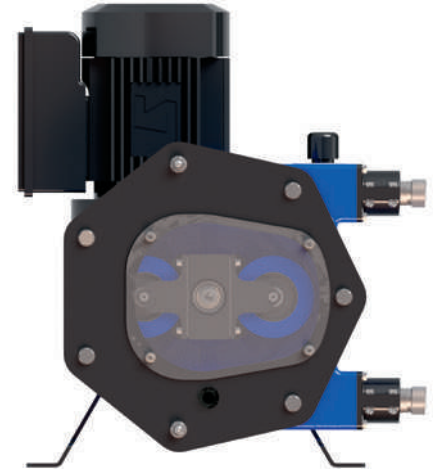

MAIN FEATURES AND BENEFITS

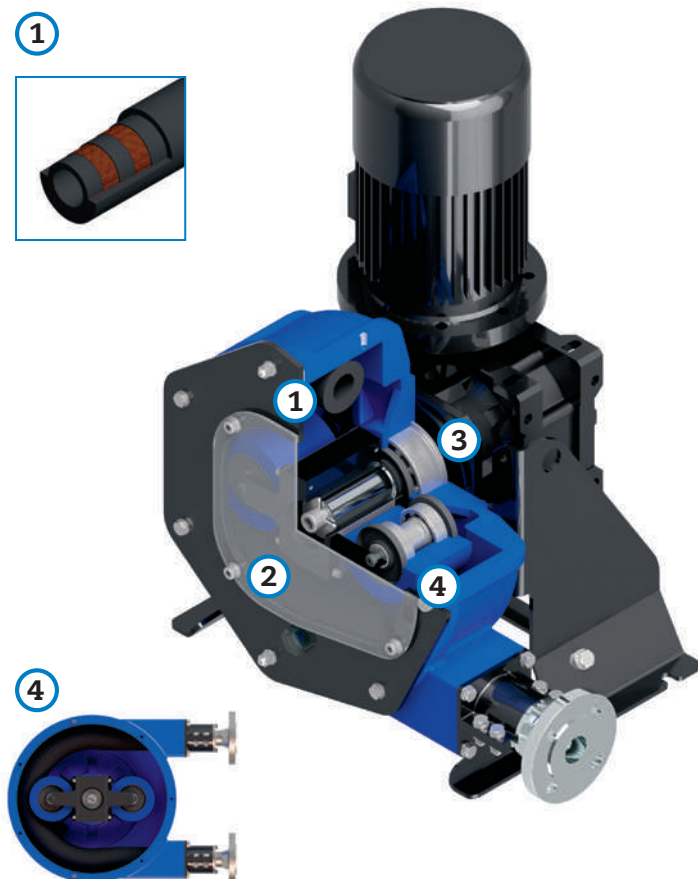

1 LATEST TECHNOLOGY PERISTALTIC HOSE.

SAVING ON HOSE CONSUMPTION AND EASE OF INSTALLATION DOWNTIME OPTIMISATION.

2 EASE OF ASSEMBLY, OPERATION AND MAINTENANCE.

SAVING ON MAINTENANCE COSTS AND EASE OF ASSEMBLY. LESS DOWNTIME.

3 EXTREMELY HEAVY DUTY DESIGN FOR THE MOST DEMANDING APPLICATIONS UP TO 10 BAR.

UNMATCHED PUMP LIFE AND EXCELLENT EQUIPMENT PERFORMANCE UNDER ANY OPERATING CONDITIONS HOWEVER DEMANDING.

4 XXL ROLLER TECHNOLOGY.

MAJOR ENERGY SAVINGS, HIGHER NUMBER OF HOSE WORKING HOURS AND EASE OF OPERATION.

**REQUIRED
MOTOR POWER (KW)**

**PRODUCT
TEMPERATURE (°C)**

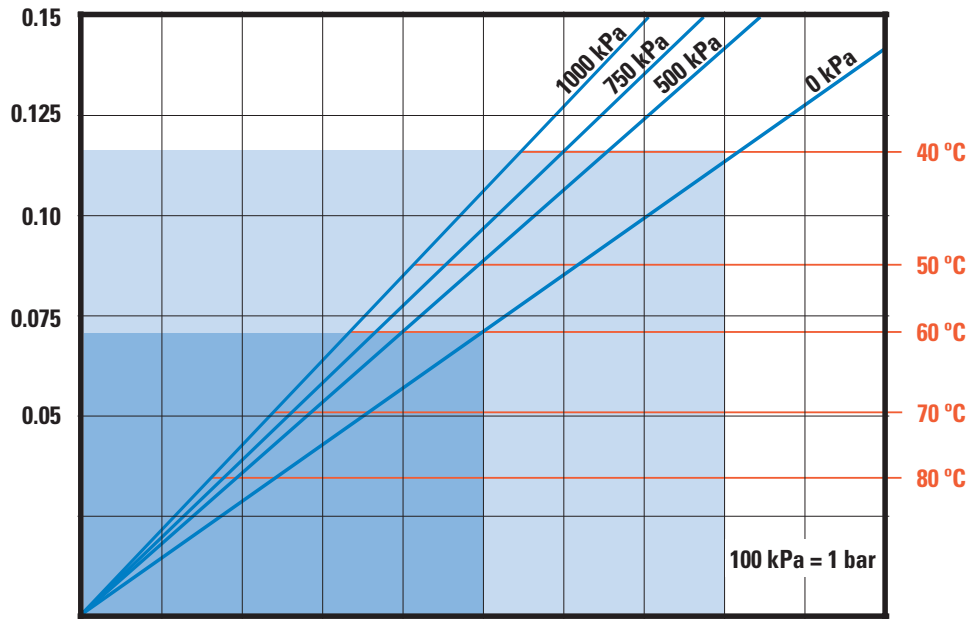

PUMP SPEED (RPM)	10	20	30	40	50	60	70	80	90	100
CAPACITY (L/H)	26	52	77	103	129	155	181	206	232	258

PRESSURE (kPa)	0 kPa	500 kPa	750 kPa	1000 kPa
TORQUE (Nm)	14	17	19	22

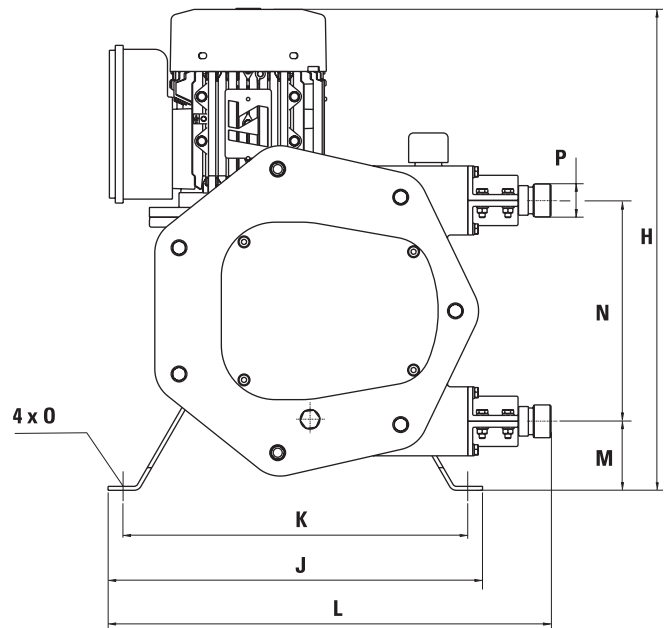
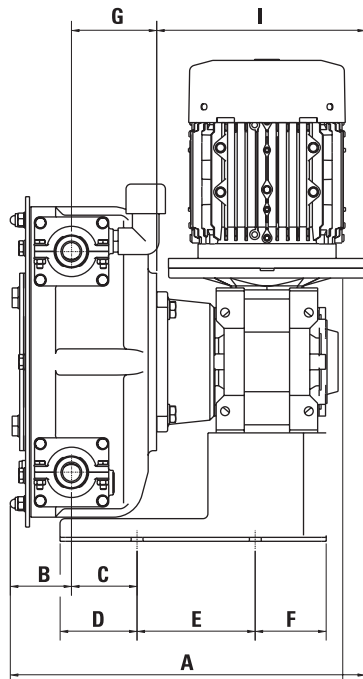

MODEL	A*	B	C	D	E	F	G	H	I*	J	K	L	M	N	O	P
I12	240,3	47,5	50	54,3	80	32,8	55,8	367	137	265	235	305	62	116	12	BSP 3/8"

*Depending on the driver, dimensions could change.