

PERIBEST I17 DATASHEET

TECHNICAL SPECIFICATIONS	MODEL I17
Max. Flow (continuous)	500 l/h
Capacity	0,109 l/rev
Max. Discharge Pressure	10 bar
Max. Temperature	80 °C
Inner Diameter	16 mm.
Hose material	NR, EPDM, NBR (Food Grade) y Hypalon®
Connections material	AISI-316, PP, PVDF (PTFE)
Pump casing material	Alluminium (powder coated)
Rollers material	Hard alluminium (Anodized)

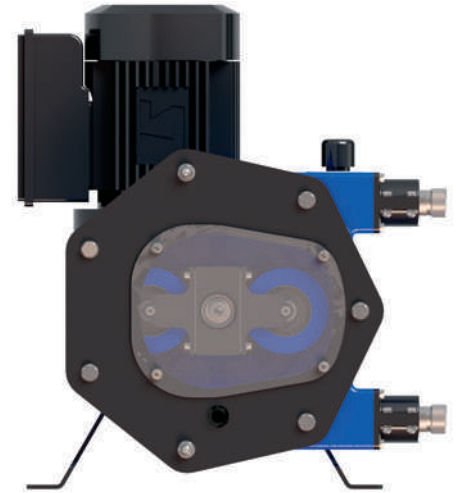

MAIN FEATURES AND BENEFITS

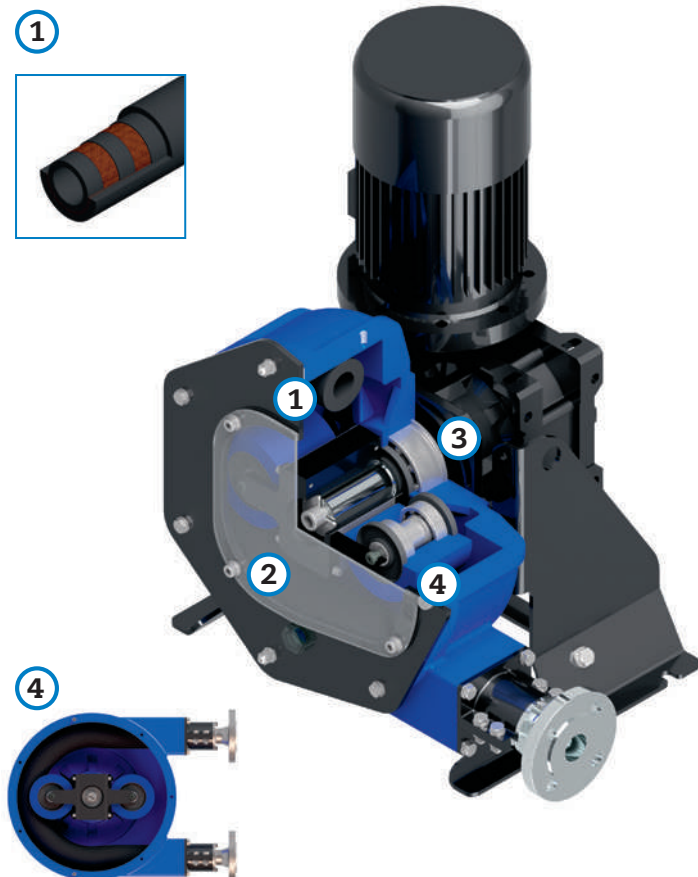

1 LATEST TECHNOLOGY PERISTALTIC HOSE.

SAVING ON HOSE CONSUMPTION AND EASE OF INSTALLATION DOWNTIME OPTIMISATION.

2 EASE OF ASSEMBLY, OPERATION AND MAINTENANCE.

SAVING ON MAINTENANCE COSTS AND EASE OF ASSEMBLY. LESS DOWNTIME.

3 EXTREMELY HEAVY DUTY DESIGN FOR THE MOST DEMANDING APPLICATIONS UP TO 10 BAR.

UNMATCHED PUMP LIFE AND EXCELLENT EQUIPMENT PERFORMANCE UNDER ANY OPERATING CONDITIONS HOWEVER DEMANDING.

4 XXL ROLLER TECHNOLOGY.

MAJOR ENERGY SAVINGS, HIGHER NUMBER OF HOSE WORKING HOURS AND EASE OF OPERATION.

**REQUIRED
MOTOR POWER (KW)**

**PRODUCT
TEMPERATURE (°C)**

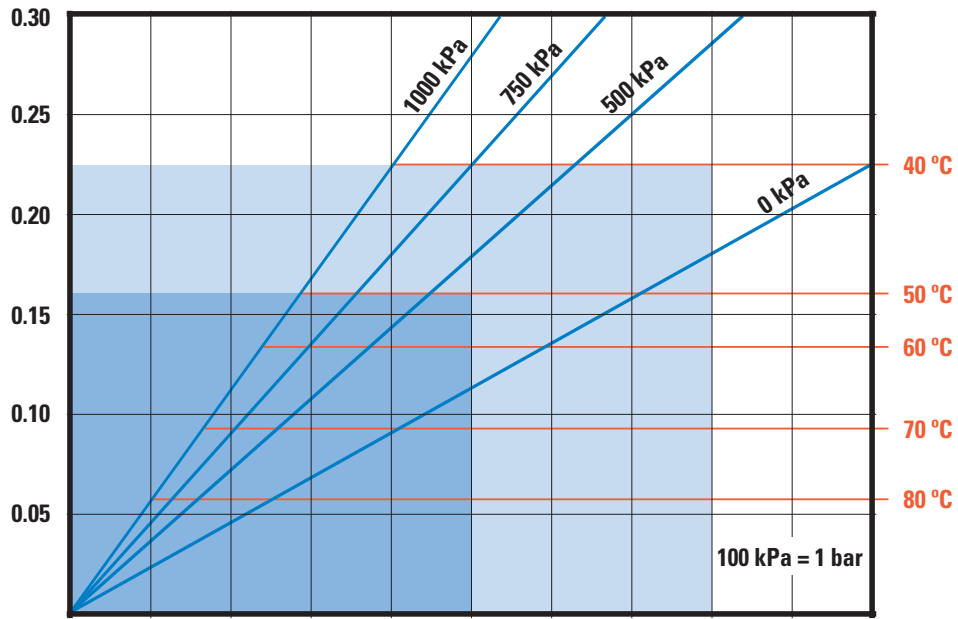

PUMP SPEED (RPM)	10	20	30	40	50	60	70	80	90	100
CAPACITY (L/H)	65	131	196	262	327	392	458	523	589	654

PRESSURE (kPa)	0 kPa	500 kPa	750 kPa	1000 kPa
TORQUE (Nm)	20	29	43	50

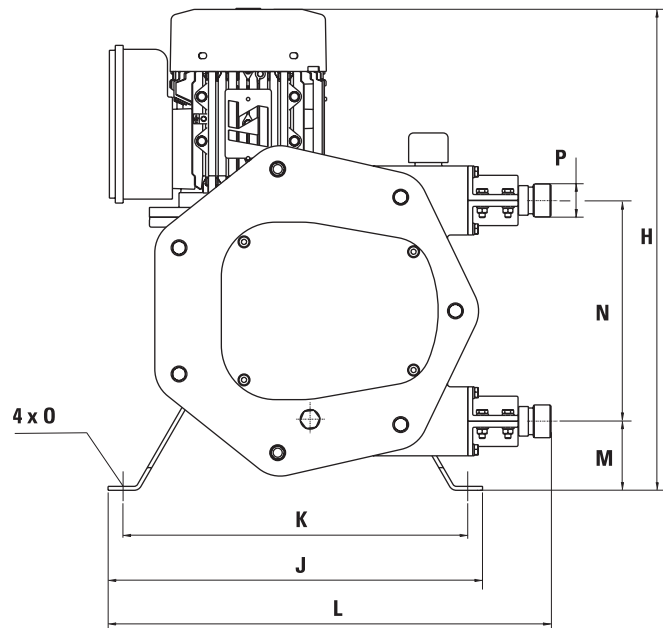
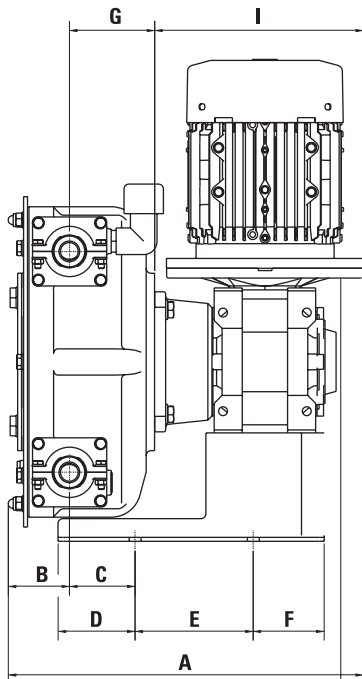

MODEL	A*	B	C	D	E	F	G	H	I*	J	K	L	M	N	O	P
I17	292,1	55,6	61	79,5	120	25,5	66,5	436,5	170	320	285	377,6	63	195	12	BSP 3/4"

*Depending on the driver, dimensions could change.

www.peribest.com

Production Plant
PeriBest Pumps S.L.
 C/ Can Parellada, num. 26 Nave 10
 Pol. Ind. Sector H
 E-08170 Montornés del Vallés
Barcelona
 Tel. +34 935 992 214